

CUSTOMER	:	
MODEL	:	XLink1602A0
SEC CODE	:	

Data Type		Datasheet	
Lang Code		English	
Total Page			
Author		tzero	/
Accepted by			/
Proposed by			/
Date			
Model Number		XLink1602A0	

Recode of Revision

XLink1602A0			
Date	Revision	Author	Description
2007/11/05	0.0.1	tzero	Document Creation
2008/12/23	1.0.0	tzero	Pin No Modify (page 6)

CONTENTS

1. FEATURES	5
2. ABSOLUTE MAXIMUM RATING	5
3. MECHANICAL PARAMETERS	5
LCM OUTLINE DIMENSION	5
VIEWING AREA	5
4. PIN ASSIGNMENT	6
5. DC CHARACTERISTIC	7
6. CHARACTERISTICS OF LCD MODULE	8
7. AC CHARACTERISTIC(VDD=2.4V~5.5V,TA=-30~+75℃)	9
7-1. WRITE OPERATION	10
7-2. READ OPERATION	10
8. SOLDERING PROFILE	11
9. PARTS LIST	12
10. CONTROL AND DISPLAY COMMAND	13
11. SPECIFICATION OF QUALITY ASSURANCE	15
11-1. ACCEPTABLE QUALITY LEVEL	15
11-2. DEFINITION OF “LOT”	15
11-3. CONDITIONS OF COSMETIC & FUNCTIONAL INSPECTION	15
12. INSPECTION CRITERIA	16
13. RELIABILITY	17
14. PRECAUTION IN USE OF LCD PANELS & LCM	18
15.1 STORAGE	18
15.2 PRECAUTION FOR HANDING LCD MODULES	18
15.3 ELECTRO-STATIC DISCHARGE CONTROL	18
15.4 PRECAUTION FOR OPERATION.....	19
15. ASSEMBLY DIAGRAM	20

1. FEATURES

- Display Type: FSTN
- Display Format: 191X24 dots
- Display Mode: Positive, Reflective
- Driving Mode: 1/27Duty, 1/6.2Bias
- Number of data line:8-bit parallel
- Operating Voltage: 5.0V
- Viewing Direction: 6 O'clock
- ROHS COMPLIANT AND LEAD FREE

2. ABSOLUTE MAXIMUM RATING

Item	Symbol	Min.	Max.	Unit
Power Supply for Logic	VDD	-0.3	+7.0	V
Power Supply for LCD Drive	Vlcd	-0.3	17.0	V
Input Voltage	Vin	-0.3	VDD+0.3	V
Operating Temperature	Ta	-20	+70	°C
Storage Temperature	Tsto	-30	+80	°C

3. MECHANICAL PARAMETERS

Item	Description	Unit
LCM Outline Dimension	122.0 x 44.0 x11.0(MAX)	mm
Viewing Area	99.0 x 24.0	mm
Weight	50	g

4. PIN ASSIGNMENT

NO.	Symbol	Level	Function	
1	VSS	--	0V	
2	VDD	--	+4.8V	Power Supply
3	VL	--	for LCD	
4	RS	H/L	Register Select	H: Data register L: Instruction register
5	R/W	H/L	H--Read	L--Write
6	E	H, H-L	Enable Signal	
7	DB0	H/L	Data bus used in 8 bit transfer	
8	DB1	H/L		
9	DB2	H/L		
10	DB3	H/L		
11	DB4	H/L		
12	DB5	H/L		
13	DB6	H/L		
14	DB7	H/L		

5. DC CHARACTERISTIC

Item	Symbol	Min	Typ	Max	Unit	Test Condon	Notes
Input high voltage(1) (except OSC1)	V_{IH1}	$0.7V_{CC}$	-	V_{CC}	V		5.6
Input low voltage(1) (except OSC1)	V_{LH1}	-0.3	-	$0.2V_{CC}$	V	$V_{CC} = 2.4$ to $3.0V$	5.6
		-0.3	-	0.6	V	$V_{CC} = 2.4$ to $4.5V$	5.6
Input high voltage(2) (OSC1)	V_{IH2}	$0.7V_{CC}$	-	V_{CC}	V		15
Input low voltage(2) (OSC1)	V_{LH2}	-	-	$0.2V_{CC}$	V		15
Output high voltage (1) (D0-D7)	V_{OH1}	$0.75V_{CC}$	-	-	V	$-I_{OH} = 0.1mA$	7
Output low voltage (1) (D0-D7)	V_{OL1}	-	-	$0.2V_{CC}$	V	$I_{OL} = 0.1mA$	7
Output high voltage (2) (except D0-D7)	V_{OH2}		-	-	V	$-I_{OH} = 0.04mA$	8
Output low voltage (2) (except D0-D7)	V_{OL2}	-	-	$0.2V_{CC}$	V	$I_{OL} = 0.04mA$	8
Driver ON resistance (COM)	R_{COM}	-	-	20	K	$I_d = 0.05mA$ $V_{LCD} = 4V$	13
Driver ON resistance (SEG)	R_{SEG}	-	-	30	K	$I_d = 0.05mA$ $V_{LCD} = 4V$	13
I/O leakage current	I_U	-1	-	1	A	$V_{IN} = 0$ to V_{CC}	9
Pull-up MOS current (RESET* pin)	$-I_P$	5	50	120	A	$V_{CC} = 3V$ $V_{IN} = 0V$	
Power supply current	I_{CC1}	-	150	300	A	Rf Oscillation, External clock $V_{CC} = 3V$ $f_{OSC} = 215kHz$	10.14
	I_{CC2}	-	25	-	A	Sleep mode $V_{CC} = 3V$ $f_{OSC} = 215kHz$	
LCD Voltage	V_{LCD}	3.0	-	15.0	V	$V_{CC} - V_5$	16

6. CHARACTERISTICS OF LCD MODULE

Item	Symbol	Test Temp.	Min.	Standard	Max.	Unit
Viewing Angle	$\Delta\theta$	25°C	20	25		° (Degree)
Contrast	Cr		3	6		
Response Time	t_r	25°C		200	250	ms
		0°C		800	1200	
		-20°C		1250	1750	
	t_d	25°C		250	300	
		0°C		1000	1500	
		-20°C		1600	2500	

The Test Condition Of Viewing Angle :

1) $Cr \geq 3$

2) 6 o'clock $\theta = 0^\circ$, 12 o'clock $\theta = 180^\circ$, 3 o'clock $\theta = 90^\circ$, 9 o'clock $\theta = 270^\circ$

a. THE DEFINITIONS OF NORMAL CHARACTERISTICS

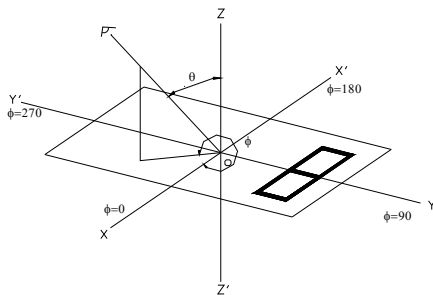

Definition of Angle ϕ, θ

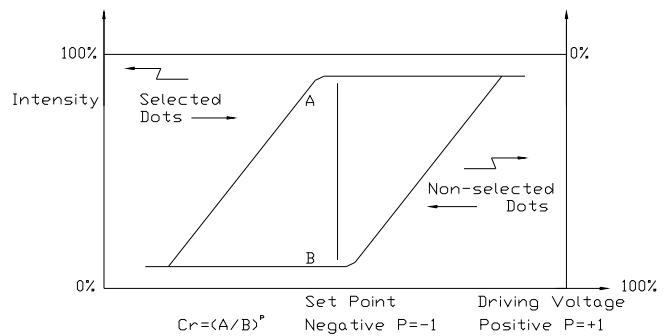

Definition of Contrast

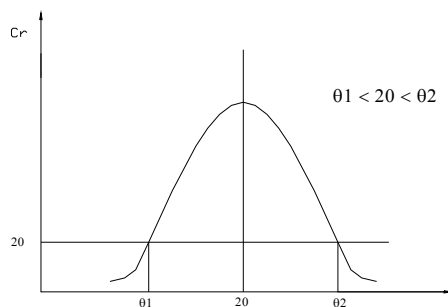

Definition of Viewing Angle

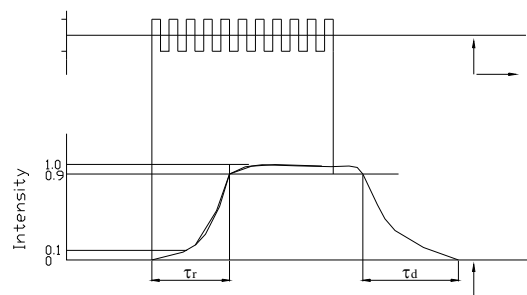

Definition of Response Time

7. AC CHARACTERISTIC(VDD=2.4V~5.5V,Ta=-30~+75°C)

Item		Symbol	Min	Typ	Max	Unit	Test Condon	Notes
External Clock Operation	External clock frequency	f_{cp}	80	215	350	kHz	$V_{cc}=2.4$ to 2.7V	11
			80	215	550	kHz	$V_{cc}=2.4$ to 2.7V	
	External clock duty	Duty	45	50	55	%		
	External clock rise time	t_{ncp}	-	-	0.2	μs		
	External clock fall time	t_{ncp}	-	-	0.2	μs		
R_f oscillation	Clock oscillation frequency(XD1602A0)	f_{osc}	110	150	200	kHz	$R_f=150$ k Ω , $V_{cc}=3V$	12

(Write mode)

Characteristic	Symbol	Min.	Typ.	Max.	Unit
E Cycle Time	T_c	500	--	--	ns
E Pulse Width (High, Low)	T_r, T_f	150	--	---	ns
E Rise/Fall Time	T_{pw}	---	--	20	ns
R/W, RS AND E Setup Time	T_{as}	40	--	--	ns
R/W, RS AND E Hold Time	T_{ah}	30	--	--	ns
DB0-DB7 Data Setup Time	T_{dsw}	80	--	--	ns
DB0-DB7 Data Hold Time	T_h	30	--	--	ns

(Read mode)

Characteristic	Symbol	Min.	Typ.	Max.	Unit
E Cycle Time	T_c	500	--	--	ns
E Pulse Width (High, Low)	T_r, T_f	230	--	---	ns
E Rise/Fall Time	T_{pw}	---	--	20	ns
R/W, RS and E Setup Time	T_{as}	40	--	--	ns
R/W, RS and E Hold Time	T_{ah}	30	--	--	ns
Data Setup Time	T_{ddr}	--	--	160	ns
Data Hold Time	T_h	5	--	--	ns

7-1. WRITE OPERATION

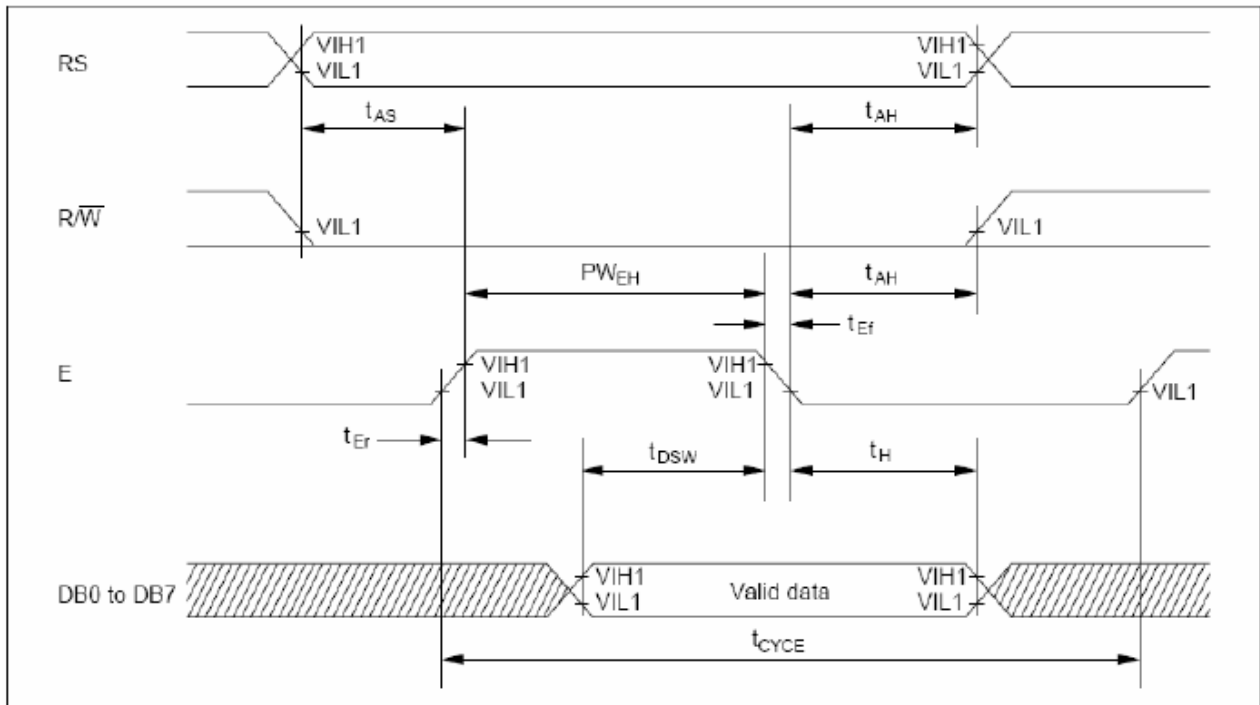

7-2. READ OPERATION

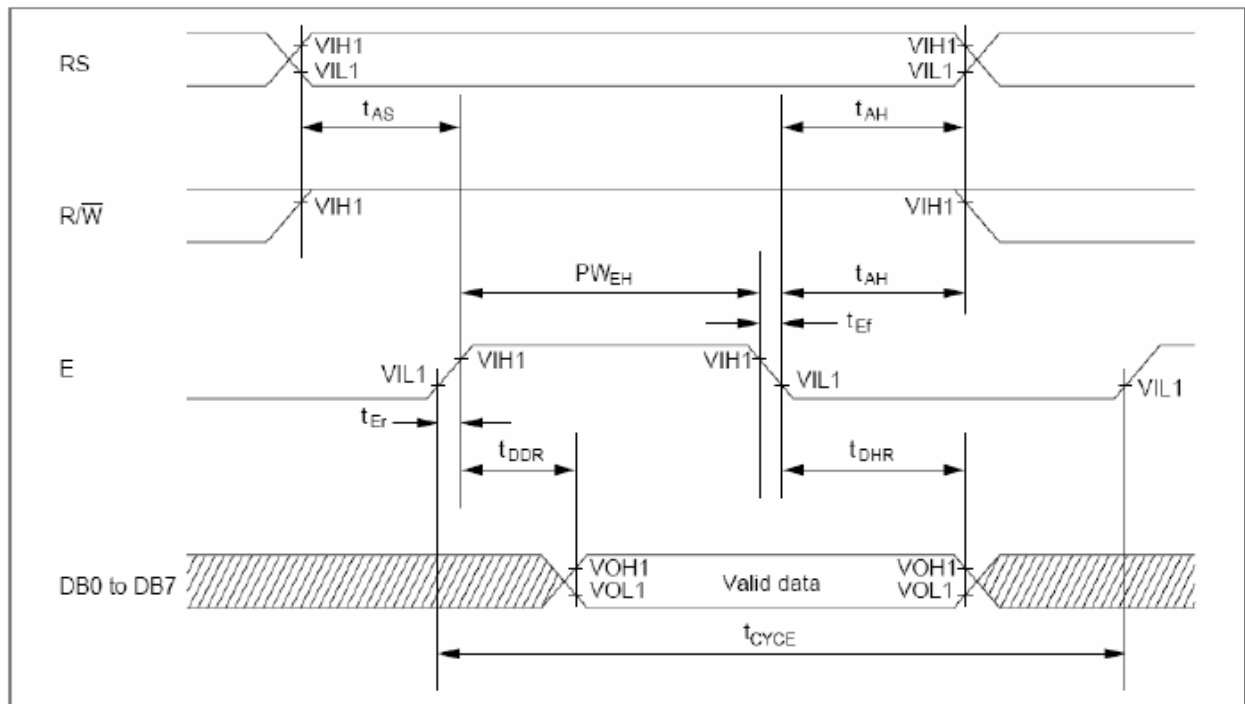

8. SOLDERING PROFILE

- a. soldering must be lead free
- b. soldering temp. (260dec)
- c. soldering time

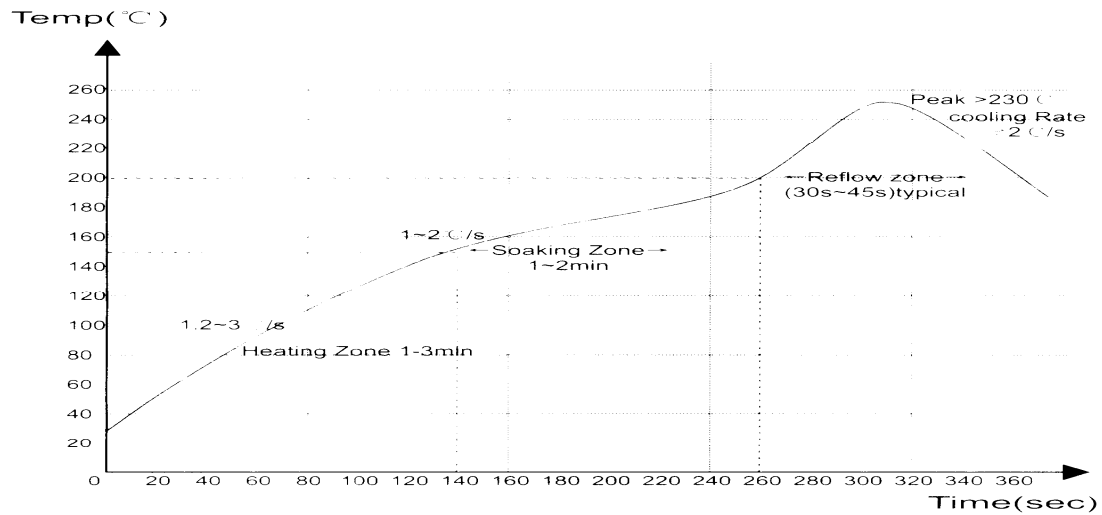

▲ 高温焊锡膏回流曲线图

9. PARTS LIST

Part	Spec	Number	Description
LCD	CSL-50215AR		
BEZEL	OPTO0419CF		
ZEBRA	OPTO0419CF		
FFC	H-125-14-84-4/2-04-18/0-0106(DST4)A		
PCB	OPTO0419CF		
RESISTOR	1/10W-J-100K	1	R9
RESISTOR	1/10W-J-4.7K	4	R4,R5,R7,R8
RESISTOR	1/10W-J-10K	1	R6
RESISTOR	1/10W-J-0R	1	R11
RESISTOR	1/10W-J-220R	4	R10,R13,R14,R15
CAPACITOR	0.1uF-Z-16V	3	C1,C7,C8
CAPACITOR	1uF-Z-16V	2	C2,C3
CAPACITOR	47pF-Z-16V	4	C4,C5,C6
TR	MMBT6428LI1G	1	Q1
IC	XD1602	1	U1
IC	S6A0065B	3	U2,U3,U4

10. CONTROL AND DISPLAY COMMAND

Reg No	Index (Hex)	Register	Code										Description	Execution Clock Cycle
			R/W	RS	DB7	DB6	DB5	DB4	DB3	DB2	DB1	DB0		
IR	—	Index (IDR)	0	0	—	—	—	—	ID3	ID2	ID1	ID0	Designates the register number of the instruction register to access. ID = 0000: R0 to 1001: R9	12
SR	—	Status (STR)	1	0	BF	NF1	NF0	-	LF3	LF2	LF1	LF0	Indicates the busy flag (BF), display read line position (NF1/0), display read rasterrow position(NL0 to NL3).	0
R0	0	Entry Mode (EMR)	0	1	0	0	0	0	0	I/D	RM1	RM0	Designates RAM address in incrementation or decrementation (I/D) and RAM selection (RM1/0).	12
R1	1	Function Set (FSR)	0	1	0	BST X	EXT2	EXT1	DT1	DT0	0	DCL	DCL Clears display (DCL) and initializes the DDRAM address. Selects duty drive ratio(DT1/0), enables extension driver (EXT2/1) and sets the booster operation on.	DCL = 1: 492 Other: 12
R2	2	Cursor Control (CCR)	0	1	0	0	0	0	CHM	C	CM1	CM0	Designates cursor-on (C) and cursor display mode(CM1/0). Executes cursor home (CHM) instruction.	12
R3	3	Display Control 1 (DCR1)	0	1	0	0	0	0	0	ST	DC	DS	Designates standby mode (ST), character display on (DC), and segment display on (DS).	12
R4	4	Display Control 2 (DCR2)	0	1	0	0	NC1	NC0	0	0	NL1	NL0	Sets the number of display characters(NC1/0) and display lines(NL1/0).	12
R5	5	Scroll Control 1 (SCR1)	0	1	0	SN1	SN0	0	SL3	SL2	SL1	SL0	Sets the display start line (SN1/0) and start raster-row (ST0 to ST3).	12
R6	6	Scroll Control 2 (SCR2)	0	1	0	0	PS1	PS0	SE4	SE3	SE2	SE1	Designates partial scroll columns (PS1/0) and scroll display line enable(SE1 to SE4).	12
R7	7	Scroll Control3 (SCR3)	0	1	0	0	SQ5	SQ4	SQ3	SQ2	SQ1	SQ0	Sets the number of dots to be scrolled (SQR0 to SQR5).	12

R8	8	RAM Address (RAR)	0	1	RA7	RA6	RA5	RA4	RA3	RA2	RA1	RA0	Resets the address address counter for DDRAM/CGRAM/SEGRAM. RAM is selected by RM1/0.	12
R9	9	RAM Data (RDR)	0/1	1	RD7	RD6	RD5	RD4	RD3	RD2	RD1	RD0	Writes or reads data to and from DDRAM/CGRAM/SEGRAM. RAM is selected by RM1/0.	12
RF	F	Test (TSR)	0	1	0	0	0	0	0	0	0	0	This is a test register. Set 00 in this register.	12

Note: The execution time depends on the input or oscillation frequency.

BF = 1: Internal processing being performed

NF1/0: Position of display read line

LF0 to LF3: Position of display read raster-row

ID= 1: Address increment

= 0: Address decrement

RM1/0: RAM selection (00/01: DDRAM, (10: GGRAM, 11: SEGRAM)

BST = X: Always Booster on (Don't care)

EXT2 = 1: Common driver extension enable

EXT1 = 1: Segment driver extension enable

DT1/0: Duty ratio (00: 1/14, 01: 1/27, 10: 1/40, 11: 1/53)

DCL = 1: Executes display-clear instruction

CHM = 1: Executes cursor-home instruction

C = 1: Cursor on

CM1/0: Designates cursor mode (00: 12th raster-row, 01: blinking, 10: white/black inverse)

ST = 1: Standby mode

DC = 1: Character display on

DS = 1: Segment display on

NC1/0: Sets the number of display characters (6 to 40 characters)

NL1/0: Sets the number of display lines (00: 1 line, 01: 2 lines, 11: 4 lines)

SN1/0: Designates the line to start displaying (00: first line, 01: second line, 10: third line, 11: fourth line)

SL0 to SL3: Designates scroll starting raster-row(0000: first raster-row, 1100: 13th raster-row)

PS1/0: Designates partial scroll (00: all columns scroll, 01: the leftmost column fixed, 10: the two leftmost columns fixed, 11: the three leftmost columns fixed)

SE1 to SE4: Designates which line to scroll (SE = 1: enables the first line to be scrolled, etc.)

SQ0 to SQ5: Number of dots to scroll (0 to 48 dots)

RA0 to RA7: RAM address

RD0 to RD7: RAM data

11. SPECIFICATION OF QUALITY ASSURANCE

11-1. Acceptable Quality Level

Each lot should be satisfied the quality level defined as follows.

-Inspection method ; MIL-STD-105E level II Normal One Time sampling.

-AQL

Partition	AQL	Definition
A: Major	0.65%	Functional defective as Product
B: Minor	1.5%	Satisfy all functions as product but not satisfy cosmetic standard

11-2. Definition of "LOT"

One lot means the delivery quantity for customer at one time.

11-3. Conditions of Cosmetic & Functional Inspection

1). Environmental Condition

The inspection should be performed at the 1m of height from the LCD module under 2 PCS of 40W white fluorescent lamps (Normal temperature 20 ~ 25°C and normal humidity 85±15%RH).

2). Inspection Method

The visual check should be performed vertically at more 30cm's distance from the LCD panel.

3). Driving Voltage

Operating voltage according to specification.

4). Test pattern

Pattern will automatically displayed according to the software.

12. INSPECTION CRITERIA

No	Item	Judgment criteria	Def.classify
1	Outline dimension	Incorrect outline dimension according to product drawing	major
2	PCB warpage	Excess warpage of PCB which may affect module assembly	minor
3	Damaged PCB	Broken PCB	major
4	Metal frame deformed	Deformed may affect module assembly	major
5	Dice epoxy improper sealing	Bonding wire protruded out of epoxy seal	major
6	Operating voltage	Module can not operate normally under designed voltage	major
7	Missing segment.	a. All dot matrix do not light up b. Part of dot does not light up	major
8	Extra pattern	Extra pattern lights up	major
9	Display pattern test	Pattern does not progress correctly according to the software	major
10	LCD rainbow	Arches, circular or parallel colorful spreads	minor
11	LCD black spot	Blank spot, foreign materials Diameter (mm) Acc. No. D<0.1 Ignore 0.1<D<0.2 1 0.2<D 0	minor
12	Dot matrix pinhole	Size (mm) Acc. No. D<0.15 Ignore 0.15<D<0.2 1	minor
13	Polarizer bubble	Bubbles with spot shape within the effective viewing area Size (mm) Acc. No. D<0.2 Ignore 0.2<D<0.3 1	minor
14	Scratch on Polarizer	Failure if scratch within the viewing area on the surface Size (mm) Acc. No. Length<1 1 Width<0.2	minor

13. RELIABILITY

No	TEST ITEM	DESCRIPTION	TEST CONDITION	REMARK	
1	ENVIRONMENTAL TEST	HIGH TEMPERATURE STORAGE	APPLYING THE HIGH STORAGE TEMPERATURE UNDER NORMAL HUMIDITY FOR A LONG TIME CHECK NORMAL PERFORMANCE.	<30%RH 80°C 100H	
2		LOW TEMPERATURE STORAGE	APPLYING THE LOW STORAGE TEMPERATURE UNDER NORMAL HUMIDITY FOR A LONG TIME CHECK NORMAL PERFORMANCE.	-20°C 100H	
3		HIGH TEMPERATURE OPERATION	APPLY THE ELECTRIC STRESS (VOLTAGE & CURRENT) UNDER HIGH TEMPERATURE FOR A LONG TIME	<30%RH 70°C 100H	#1
4		LOW TEMPERATURE OPERATION	APPLY THE ELECTRIC STRESS UNDER LOW TEMPERATURE FOR A LONG TIME	-20°C 100H	#1 #2
5		HIGH TEMPERATURE/HIGH HUMIDITY STORAGE	APPLY HIGH TEMPERATURE AND HIGH HUMIDITY STORAGE FOR A LONG TIME	93%RH 40°C 100H	#2
6		TEMPERATURE CYCLE	APPLY THE LOW AND HIGH TEMPERATURE CYCLE -20°C<->25°C<->70°C<->25°C ←-----> 1CYCLE CHECK NORMAL PERFORMANCE	-20°C/70°C 10CYCLE	
7	MECHANICAL TEST	VIBRATION TEST (PACKAGE STATE)	APPLYING VIBRATION TO THE PRODUCT CHECK NORMAL PERFORMANCE	FREQ: 1-55HZ MAX. ACCELERATION: 5G 1CYCLE TIME: 1 MIN TIME X.Y.X. EACH DIRECTION FOR 15 MINES.	
8		SHOCK TEST (PACKAGE STATE)	APPLYING SHOCK TO THE PRODUCT CHECK NORMAL PERFORMANCE	DROP THEM THROUGH 70CM HEIGHT TO STRIKE HORIZONTAL PLANE	
9	OTHER	LIFE TIME	EXPECTED LIFE IS MORE THAN 50000 HRS	NORMAL OPERATION CONDITION	

Remark:

#1: Normal operations condition

a. Power supply for LCD driver : 8.0V

b. Power supply voltage for LCD system: Getting optimum contrast at 25°C.

#2: Pay attention to keep dewdrops from the module during this test

14. PRECAUTION IN USE OF LCD PANELS & LCM

15.1 Storage

When long term storage is required, the following precautions are necessary.

- (1) Store them in a sealed polyethylene bag (Antistatic type), seal the opening, and store it where it is not subjected to direct sunshine, or to the light of a fluorescent lamp. If properly sealed, there is no need for desiccant.
- (2) Store them in the temperature range of 0°C -35°C and low humidity is recommended.

15.2 Precaution for handing LCD modules

LCD modules are assembled and adjusted with a high degree of precision, do not applying excessive shocks to it or making any alterations or modifications to it. The following precautions should be taken when handing.

- (1) Do not drop, bend or bend or twist the module.
- (2) Do not alter or making any modification on the shape of the metal frame.
- (3) Do not change the shape, the pattern wiring or add any extra hole on the printed circuit board.
- (4) Do not modify or touch the zebra rubber strip (conductive rubber) with another object.
- (5) Do not change the positions of components on the PCB.

15.3 Electro-static discharge control

Careful attention should be paid to control the electrostatic discharge of the modules, since LCD modules contain no. of COMS LSI.

- (1) Make sure you are grounded properly when removing LCD module from its antistatic bag. Be sure that the module and your body have the same electric potential.
- (2) Only properly grounded soldering iron should be used.
- (3) Modules should store in antistatic bag or other containers resistant to static after remove from its original package.
- (4) When using the electric screwdriver is used, make sure the screwdriver had been ground potentiality

to minimize the transmission of EM waves produced by commutator sparks.

- (5) In order to reduce the generation of static electricity, a relative humidity of 50-60% is recommended.
- (6) Electrostatic discharge value:4 KV.

15.4 Precaution for operation

- (1) Adjust liquid crystal driving voltage (V_o) to varies viewing angle and obtain the best contrast.
- (2) V_o should be kept in proper range stated in the specification. Excess voltage will shorten the LCD life.
- (3) Response time is greatly delayed at temperatures below the operating temperature range. It will recover when it returns to the specified temperature range.
- (4) If the display area is pushed hard during operation, the display will become abnormal. However, it will return off and then back on.
- (5) Condensation on terminals can cause an electrochemical reaction disrupting the terminal circuit. Therefore it must be used under the relative condition of 50% RH.

15. ASSEMBLY DIAGRAM

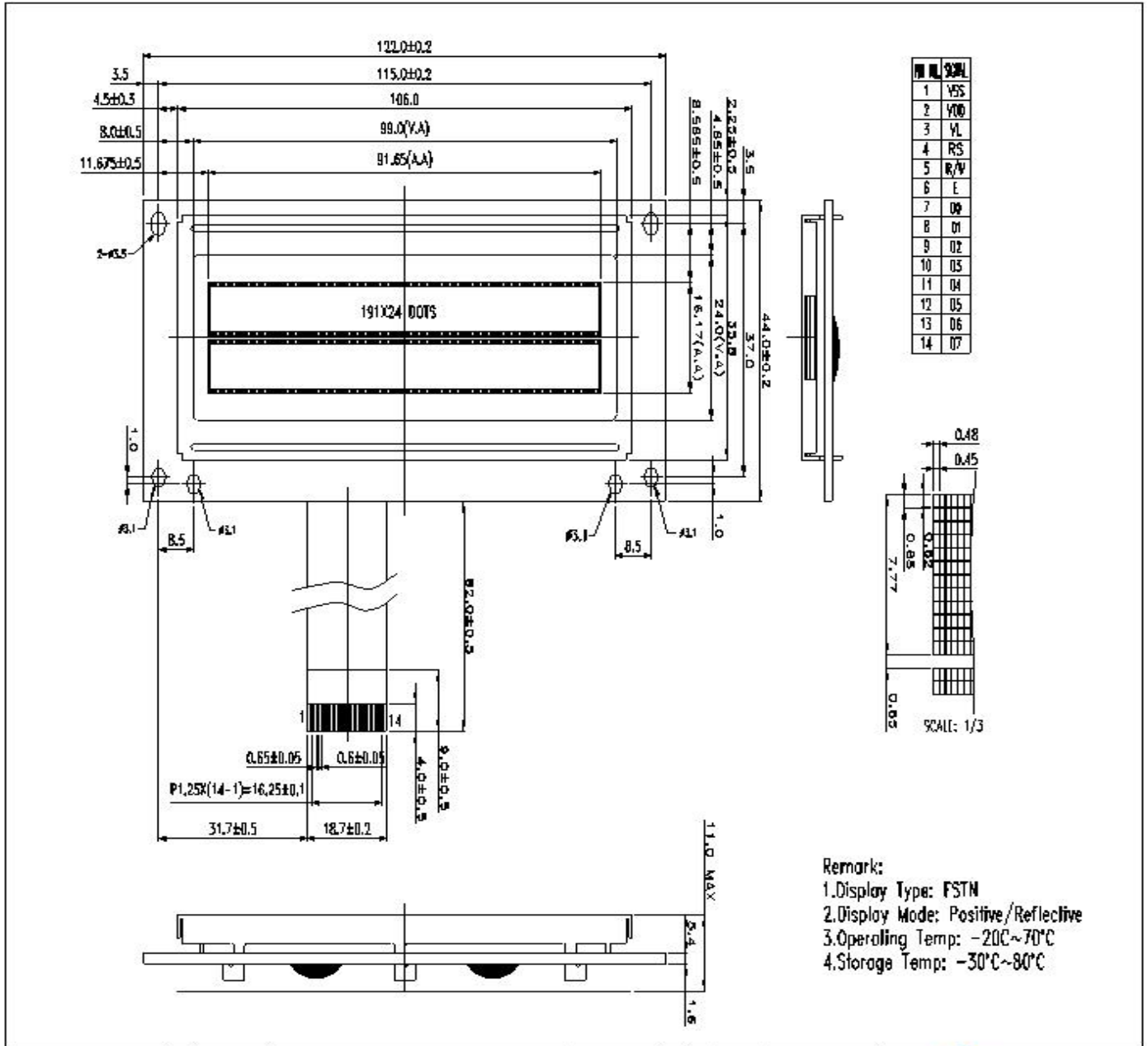

Remark:
 1. Display Type: FSTN
 2. Display Mode: Positive/Reflective
 3. Operating Temp: -20°C~70°C
 4. Storage Temp: -30°C~80°C

				ELECTRICAL		1/27 DUTY CYCLE		DSYS Technologies	
						1/6.2 BIASING		TITLE LCW	
						4.0V OPERATING VOLTAGE		PRODUCT NO. OPTCD419CF	
						6 O'CLOCK VIEWING DIRECTION		REV. A SHEET OF 1/1	
REV.	DATE	NO OF REVISION	STATUS	APPROVAL	DATE	DWN LYY 05.8.23		CHKD	
						PROJECTION 3RD		TOLERANCE UNLESS SPECIFIED ±0.2	
								UNIT mm SCALE 1/1	